

IMI PBM IGENIX® 3, 4, or 5-WAY MULTI-PORT BALL VALVES



MI SERIES 5, CL 150#, 1/2" - 4"

DESIGN FEATURES:

- Unique Adjust-O-Seal® feature allows in-line valve adjustment to compensate for normal wear on valve seats.
- **MI Series Multi-Port valves DO NOT have o-rings.**
- Choose from 4-way and 5-way flow patterns available offering for 90°, 180° and 360° operation
- Full-port diameters minimize pressure drops (1/2 - 4")
- True-Bore® (tube) for sanitary valves
- Upstream and downstream bubble-tight sealing capability allows valve body cleaning, purging, and draining.
- Stem assembly accommodates IMI PBM Direct Mount Actuation for accurate alignment and increased cycling life.
- In some processes, a single Multi-Port ball valve can replace several 2-way valves in a piping system, reducing costs and simplifying flow control with actuation.
- Full port design
- Valves are rated to full vacuum.
- Specify IMI PBM flow pattern for 3, 4, or 5-way valves.
- Piggable "Y" Port valves are also available. Contact IMI PBM.
- Certified Material Test Report (CMTRS) provided for wetted components
- Surface finishes are achieved without the use of ADIs (Animal Derived Ingredients)



SPECIFICATIONS	SANITARY MULTI-PORT VALVES
Sizes	1/2" - 4" Series 5
Material	316L Stainless Steel
Temperatures	Ambient for V-TEF™ to 450° F depending on seat and seal material
End Connections	Extended tube, hygienic clamp, or others
Seats, Seals and Stem Packings	V-TEF™ material standard, others available
Body Bolts & Nuts	18-8 Stainless Steel
Maximum Working Pressure	up to 275 psig CWP depending on valve size and temperature
Polish	Standard internal polish of 63 Ra maximum

CV Values (gpm)			
Size	L-Port	T-Port	
		Straight	Branch
1/2"	3.8	3.8	2.5
3/4"	12	12	7
1"	25	25	15
1-1/2"	66	66	40
2"	129	129	78
3"	310	310	185
4"	570	570	340

ID Surface Finish, Ra Readings for Valves per ASME BPE			
Surface Finish	IMI PBM Polish Code	μ-in.	μ-m.
Mechanical Polish			
SF 1	A	20 Ra max	0.51
SF 2	A	25 Ra max	0.64
SF 3	-	30 Ra max	0.76
Mechanical Polish and Electropolish			
SF 4	G	15 Ra max	0.38
SF 5	F	20 Ra max	0.51
SF 6	F	25 Ra max	0.64

How To Order:

PRODUCT (1-2)		MATERIAL (3-4)		SIZE (5)		SERIES (6)		END CONN. (7-8)		SEAT & SEAL (9)		FLOW PATTERNS (10-11)		BALL & STEM (12)		OPERATOR (13-14)		POLISH (15-16)	
MI	HL	Cast	316L S / S	C	1/2"	5	X-	Hygienic Clamp	G	V-TEF™ Seats / Seals	01	3-Way Side Entry T-Port Ball 90°	-	Standard Ball and Stem	--	W/ Standard Lever Handle (1/2" thru 3")	-	63 Ra ID Standard	
				D	3/4"		F-	Ext. Butt weld for Tube	J	V-TEF™ Seats / Seals VTFE Cavity Fillers	02	3-Way Side Entry T-Port Ball 90°	F	Internal / External Grounding	02	W/O Handle W/ Stem Actuator Prep	A	20 Ra ID	
				E	1"				H	S-TEF® Seats / Seals	18	3-Way Btm. Entry LL-Port Ball 90°	G	17-4PH Stem	04	Locking Lever Handle (1/2" thru 2")	C	20 Ra ID / 32 Ra OD	
				G	1-1/2"				I	S-TEF® Seats / Seals VTFE Cavity Fillers	26	4-Way Btm. Entry L-Port Ball 360°			08	Gear Operator (Req'd for 4")	F	20 Ra ID after Electro Polish	
				H	2"				K	UHMWPE Seats / Seals	37	4-Way Side Entry LL-Port Ball 90°			20	DA 80psig actuator			
				K	3"				L	UHMWPE Seats / Seals VTFE Cavity Fillers	44	5-Way Btm. Entry L-Port Ball 360°			27	DA 60psig actuator			
				L	4"										34	SR 80psig actuator - Fail Position must be specified			
															41	SR 60psig actuator - Fail Position must be specified			

<http://pbmvalve.com/build-a-part-number>

Other seat/seal options available - Contact PBM.

Other Flow Pattern Options available - Contact PBM.

Other operator options available - Contact PBM.

More polish available - Contact PBM.

IMI PBM IGENIX® MULTI-PORT BALL VALVES

Multi-port with Locking Handle

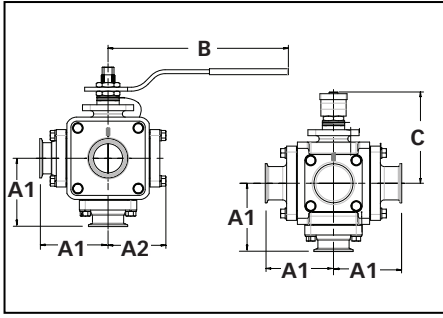

Multi-port with Butt-weld Ends

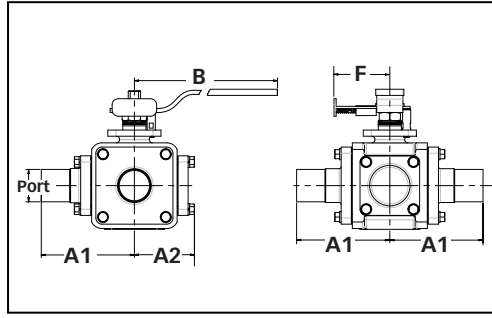

Multi-port with Gear Operator (6" only)

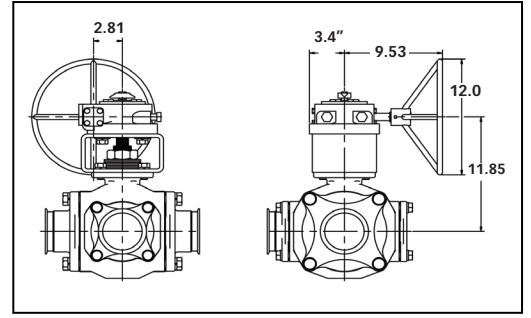

Valve Size	Size Code	Port Dia.	A1		A2	B	C	Locking Handle		Approx. Weight
			Ø to Face		Ø to Blank	Handle Length from Ø	Ø to Top of Handle	F	Hole Dia. for Lock	
			F-	X-						
1/2"	C	0.37	3.50	2.75	2.00	5.09	3.11	2.08	.28	7 lbs.
3/4"	D	0.62	3.75	2.75	2.00	5.09	3.15	2.08	.28	7 lbs.
1"	E	0.87	4.00	3.00	2.23	8.81	5.00	2.56	.38	9.4 lbs.
1-1/2"	G	1.37	5.00	3.75	3.12	11.56	5.53	3.41	.38	27 lbs.
2"	H	1.87	5.75	4.38	3.71	11.56	6.23	3.45	.38	40 lbs.
3"	K	2.87	8.11	6.50	5.46	24.06	8.77	NA	NA	89 lbs.
4"	L	3.84	NA	7.50	6.63	NA	NA	NA	NA	*161 lbs.

* Weight without handle.

1. An actuator or gear operator is recommended for 4" valves.
2. 3" and 4" bottom entry end connections only available as sanitary clamp.
3. Using a welded connection for more than one end fitting on the MI Series valve may complicate maintenance. Provisions must be made to allow removal of end fittings and body from the line.

ACTUATED DIMENSIONS

Unit of Measure = inches
Dimensions based on actuators used with V-TEF™ seats.

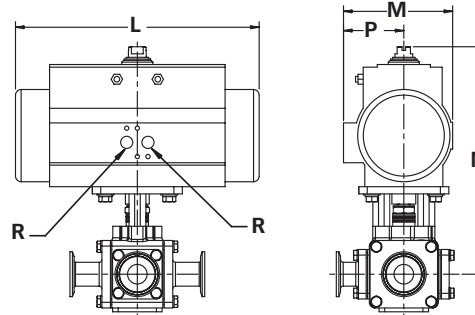

Size	80 PSI Double Acting					60 PSI Double Acting					80 PSI Spring Return					60 PSI Spring Return				
	L	M	N	P	R	L	M	N	P	R	L	M	N	P	R	L	M	N	P	R
1/2"	4.45	2.8	6.88	1.61	1/8	4.45	2.8	6.88	1.61	1/8	8.27	3.72	7.59	2.07	1/8	9.47	4.17	8.14	2.3	1/8
3/4"	4.45	2.8	6.88	1.61	1/8	4.45	2.8	6.88	1.61	1/8	8.27	3.72	7.59	2.07	1/8	9.47	4.17	8.14	2.3	1/8
1"	8.27	3.72	9	2.07	1/8	8.27	3.72	9	2.07	1/8	10.83	4.84	10	2.68	1/4	13.11	5.39	11.4	2.87	1/4
1-1/2"	13.11	5.39	13.58	2.87	1/4	13.11	5.39	13.58	2.87	1/4	14.65	5.83	13.06	3.15	1/4	17.13	6.46	14.95	3.44	1/4
2"	13.11	5.39	14	2.87	1/4	13.11	5.39	14	2.87	1/4	14.65	5.83	13.48	3.15	1/4	17.13	6.46	15.38	3.44	1/4
3"	13.11	5.39	15.67	2.87	1/4	14.65	5.83	14.5	3.15	1/4	19.69	7.36	18	3.9	1/4	22.78	8.58	20.25	4.29	1/4
4"	22.78	8.58	22.25	4.29	1/4	22.78	8.58	22.25	4.29	1/4	22.78	8.58	22.25	4.29	1/4	26.46	11.42	27	5.71	1/4

IMI PBM INDUSTRIAL 3, 4, or 5-WAY MULTI-PORT BALL VALVES



MP SEREIS 5, CL 150#, 1/2" - 4"

DESIGN FEATURES:

- Unique Adjust-O-Seal® feature allows in-line valve adjustment to compensate for normal wear on valve seats.
- **MP Series Multi-Port valves DO NOT have o-rings.**
- Choose from 4-way and 5-way flow patterns available offering for 90°, 180° and 360° operation
- Full-port diameters minimize pressure drops (1/2 - 4")
- Upstream and downstream bubble-tight sealing capability allows valve body cleaning, purging, and draining.
- Stem assembly accommodates PBM Direct Mount Actuation for accurate alignment and increased cycling life.
- In some processes, a single Multi-Port ball valve can replace several 2-way valves in a piping system, reducing costs and simplifying flow control with actuation.
- Full port design
- Valves are rated to full vacuum.
- Specify PBM flow pattern for 3, 4, or 5-way valves.
- Piggable "Y" Port valves are also available. Contact PBM.

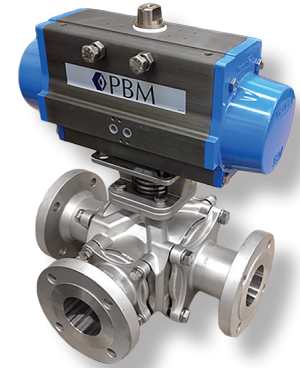

SPECIFICATIONS	Multi-Ported Ball Valves
Sizes	1/2" - 4" Series 5
Material	316/316L Stainless Steel
Temperatures	Ambient for V-TEF™ to 400° F, S-TEF® to 450° F
End Connections	Buttweld for pipe, flange, NPT, Socket weld, or other
Seats, Seals and Stem Packings	V-TEF™ material standard, others available
O-Ring	O-ring seal (FKM V1274-75/80, EPR E3608-70, others available)
Body Bolts & Nuts	18-8 Stainless Steel
Maximum Working Pressure	up to 275 psig CWP depending on valve size and temperature

Size	CV Values (gpm)			
	L-Port	T-Port		LL-Port
		Straight	Branch	
1/2"	6.6*	6.6*	5.4*	6.0*
3/4"	16*	16*	12*	14*
1"	33	33	21	30
1-1/2"	80	80	49	72
2"	147	147	89	126
3"	351	351	212	295
4"	613	613	368	443

* FNPT ends

How To Order:

PRODUCT (1-2)		SIZE (5)		END CONN.		SEAT & SEAL		FLOW PATTERNS		BALL & STEM		OPERATOR		POLISH			
MATERIAL (3-4)		SERIES (6)		(7-8)		(9)		(10-11)		(12)		(13-14)		(15-16)			
MP	H-	Cast 316/316L S/S	C	1/2"	5	B-	Sch. 40 Butt Weld	G	V-TEF™ Seats / Seals	01	3-Way Side Entry T-Port Ball 90°	-	Standard Ball and Stem	--	W/ Standard Lever Handle (1/2" thru 3")	-	125 Ra ID Standard
	HL	Cast 316L S/S	D	3/4"		D-	Sch. 10 Butt Weld	J	V-TEF™ Seats / Seals VTFE Cavity Fillers	02	3-Way Side Entry T-Port Ball 90°	F	Internal / External Grounding	02	W/O Handle W/ Stem Actuator Prep	A	20 Ra ID
			E	1"		L-	150# Flange	H	S-TEF® Seats / Seals	18	3-Way Btm. Entry LL-Port Ball 90°	G	17-4PH Stem	04	Locking Lever Handle (1/2" thru 2")	C	20 Ra ID / 32 Ra OD
			G	1-1/2"		Q-	Female NPT	I	S-TEF® Seats / Seals VTFE Cavity Fillers	26	4-Way Btm. Entry L-Port Ball 360°			08	Gear Operator (Req'd for 4")		
			H	2"		U-	Socket Weld	K	UHMWPE Seats / Seals	37	4-Way Side Entry LL-Port Ball 90°			20	DA 80psig actuator	F	20 Ra ID after Electro Polish
			K	3"				L	UHMWPE Seats / Seals VTFE Cavity Fillers	44	5-Way Btm. Entry L-Port Ball 360°			27	DA 60psig actuator		
			L	4"										34	SR 80psig actuator - Fail Position must be specified		More polish available - Contact PBM.
														41	SR 60psig actuator - Fail Position must be specified		

<http://pbmvalve.com/build-a-part-number>

Other seat/seal options available - Contact PBM.

Other Flow Pattern Options available - Contact PBM.

Other operator options available - Contact PBM.

PBM Industrial Multi-ported Ball Valves

Multi-port with Locking Handle

Multi-port with flanged ends

Multi-port with Gear Operator (6" only)

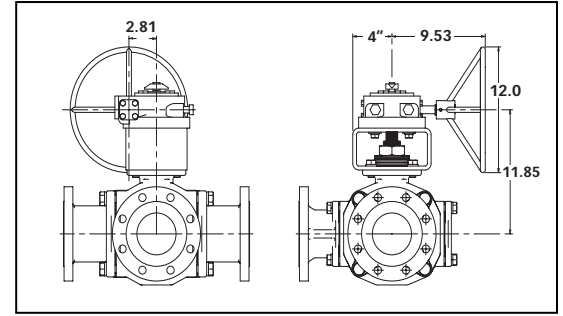
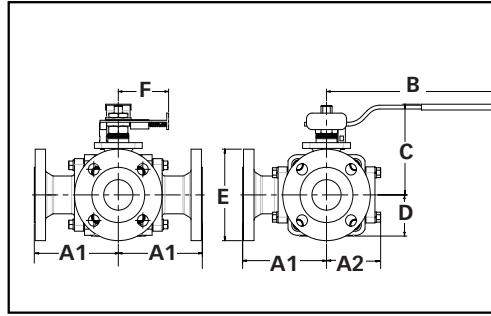
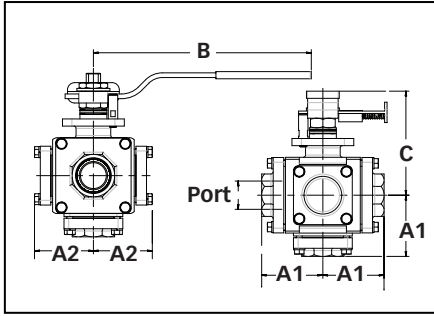

Valve Size	Size Code	Port Dia.	A1		A2	B	C	D	E	Locking Handle		Socket Weld Dia.	Approx. Weight
			Q to Face		Q to Blank	Handle Length from Q	Q to Top of Handle	Q to Bottom Side Entry	150# Flange Dia.	F	Hole Dia. for Lock		
			Q-U-	L-	Q-U-L-								
1/2"	C	0.5	2.25	NA	2.00	5.09	3.1	1.44	NA	2.08	.28	0.87	7 lbs.
3/4"	D	0.75	2.25	NA	2.00	5.09	3.1	1.44	NA	2.08	.28	1.08	7 lbs.
1"	E	1	2.38	3.75	2.23	8.03	4	1.67	4.25	2.56	.38	1.34	10.5 lbs.
1-1/2"	G	1.5	3.25	5	3.13	11.56	5.53	2.22	5	3.41	.38	1.93	26.8 lbs.
2"	H	2	3.75	5.75	3.71	11.56	6	2.7	6	3.45	.38	2.42	40.5 lbs.
3"	K	3	6	8.25	5.45	NA	NA	3.75	7.5	NA	.44	3.55	100 lbs.
4"	L	4	NA	9.5	6.63	NA	NA	4.88	9	NA	NA	NA	214 lbs.

* A gear operator is recommended for 4" valves.

ACTUATED DIMENSIONS

Unit of Measure = inches
Dimensions based on actuators used with V-TEF™ seats.

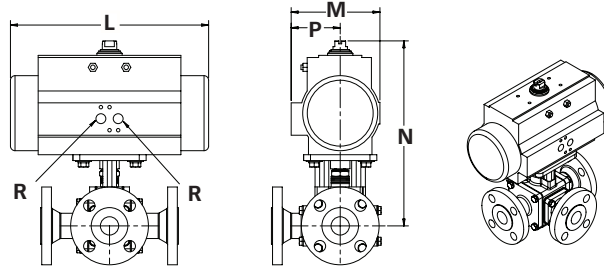

Size	80 PSI Double Acting					60 PSI Double Acting					80 PSI Spring Return					60 PSI Spring Return				
	L	M	N	P	R	L	M	N	P	R	L	M	N	P	R	L	M	N	P	R
1/2"	4.45	2.8	6.88	1.61	1/8	4.45	2.8	6.88	1.61	1/8	8.27	3.72	7.59	2.07	1/8	9.47	4.17	8.14	2.3	1/8
3/4"	4.45	2.8	6.88	1.61	1/8	4.45	2.8	6.88	1.61	1/8	8.27	3.72	7.59	2.07	1/8	9.47	4.17	8.14	2.3	1/8
1"	8.27	3.72	9	2.07	1/8	8.27	3.72	9	2.07	1/8	10.83	4.84	10	2.68	1/4	13.11	5.39	11.4	2.87	1/4
1-1/2"	13.11	5.39	13.58	2.87	1/4	13.11	5.39	13.58	2.87	1/4	14.65	5.83	14.06	3.15	1/4	17.13	6.46	14.95	3.44	1/4
2"	13.11	5.39	14	2.87	1/4	13.11	5.39	14	2.87	1/4	14.65	5.83	14.5	3.15	1/4	17.13	6.46	15.38	3.44	1/4
3"	13.11	5.39	15.67	2.87	1/4	14.65	5.83	14.5	3.15	1/4	19.69	7.36	18	3.9	1/4	22.78	8.58	20.25	4.29	1/4
4"	22.78	8.58	22.25	4.29	1/4	22.78	8.58	22.25	4.29	1/4	22.78	8.58	22.25	4.29	1/4	26.46	11.42	27	5.71	1/4

www.PBMValve.com

PBM, Inc. • 1070 Sandy Hill Road, Irwin, PA 15642

Phone: 800.967.4PBM • 724.863.0550

E-mail: info.pbmvalve@imi-critical.com



© Copyright 2020 PBM, Inc. PB-MP5