

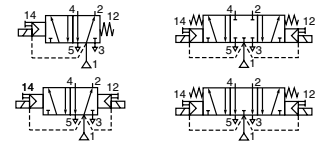

SOLENOID VALVES

pilot operated, spool type
single/dual solenoid (mono/bistable function, W1/W3)
stainless steel body, 1/4 - 1/2



5/2

5/3

Series

551-553

FEATURES

- The monostable spool valves in conformity with IEC 61508 Standard (2010 route 2_H version) have TÜV (551 series) and EXIDA (551-553 series) certified with integrity levels: SIL 2 for HFT = 0 / SIL 3 for HFT = 1
- The 5/2 and 5/3 solenoid operated spool valves have threaded port connections
- All the exhaust ports of this spool valve are connectable, providing better environmental protection, particularly recommended for sensitive areas such as clean rooms, and applications in the pharmaceutical and food processing sectors
- The valve offers environmental protection against the ingress of liquids, dusts or any other foreign matter (environmentally-protected construction)
- Can be externally piloted (external air pilot supply) to convert valve to zero minimum operation by flipping a gasket
- The solenoid valves satisfy all relevant EU Directives

GENERAL

Differential pressure (*) 2 - 10,4 bar [1 bar = 100 kPa]
Flow (Qv at 6 bar) 1/4 = 860 l/min (5/2) ; 760 l/min (5/3) (ANR)
1/2 = 3000 l/min

fluids (*)	temperature range (TS)	seal materials (*)
air, inert gas, filtered	551 : - 40°C to + 80°C	VMQ (silicone) + PUR (polyurethane)
	553 : - 40°C to + 60°C	

MATERIALS IN CONTACT WITH FLUID

(*) Ensure that the compatibility of the fluids in contact with the materials is verified

Body	Stainless steel, AISI 316L
End cover (spring)	Stainless steel
Spool valve internal parts	Stainless steel, POM
Pilot end-cover	Stainless steel
Core tube	Stainless steel
Core and plugnut	Stainless steel
Core spring	Stainless steel
Sealings & discs	NBR
Top disc	FPM
Disc holder	POM
Cartridge (Low power)	Welded, packless AISI 430
Seat	Stainless steel
Seat insert	POM
Shading coil	Silver
Rider ring (Low power)	PTFE (NF/WSNF solenoids only)

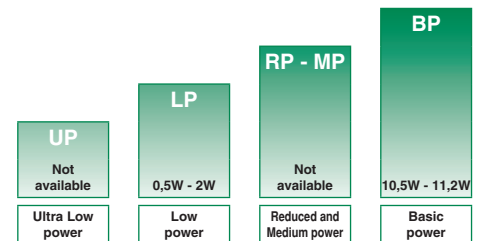
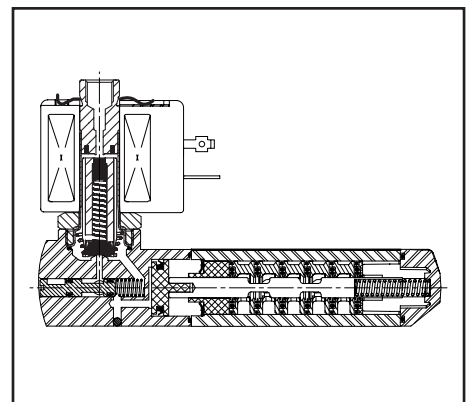

POWER LEVELS - cold electrical holding values (watt)

SPECIFICATIONS

pipe size	orifice size	flow coefficient kv		operating pressure differential (bar)			power level	prefix optional solenoids										basic catalogue number
				min. ⁽²⁾	max. (PS)			NEMA 7 & 9	ATEX / IECEx					IP65				
					air (*)				Ex d	Ex e mb	Ex mb	Ex ia	-					
(*)	(mm)	(m³/h)	(l/min)		~	=	~/=	EF	LPKF	NF	-	EM	PV	WS(LI)	-	SC		
5/2 - Solenoid air pilot operated - spring return (monostable)																		
1/4	6	0,75	12,5	0 / 2	10	10	BP	-	-	●	-	●	-	-	-	●	❖551A421 ⁽¹⁾	
1/4	6	0,75	12,5	0 / 2	10	10	BP	●	-	-	-	-	-	-	-	-	❖551G421 ⁽¹⁾	
1/4	6	0,75	12,5	0 / 2	10	10	LP	-	●	●	-	●	○	○	-	●	❖551A321 ⁽¹⁾	
1/4	6	0,75	12,5	0 / 2	10	10	LP	○	-	-	-	-	-	-	-	-	❖551G321 ⁽¹⁾	
1/2	13	2,49	41,5	0 / 2	10	10	BP	-	-	●	-	●	-	-	-	●	❖553A421 ⁽¹⁾	
1/2	13	2,49	41,5	0 / 2	10	10	BP	●	-	-	-	-	-	-	-	-	❖553G421 ⁽¹⁾	
1/2	13	2,49	41,5	0 / 2	10	10	LP	-	●	●	-	●	○	○	-	●	❖553A321 ⁽¹⁾	
1/2	13	2,49	41,5	0 / 2	10	10	LP	○	-	-	-	-	-	-	-	-	❖553G321 ⁽¹⁾	
5/2 - Solenoid air pilot operated and return (bistable)																		
1/4	6	0,75	12,5	0 / 2	10	10	BP	-	-	●	-	●	-	-	-	●	❖551A422	
1/4	6	0,75	12,5	0 / 2	10	10	BP	●	-	-	-	-	-	-	-	-	❖551G422	
1/4	6	0,75	12,5	0 / 2	10	10	LP	-	●	●	-	●	○	○	-	●	❖551A322	
1/4	6	0,75	12,5	0 / 2	10	10	LP	○	-	-	-	-	-	-	-	-	❖551G322	
1/2	13	2,49	41,5	0 / 2	10	10	BP	-	-	●	-	●	-	-	-	●	❖553A422	
1/2	13	2,49	41,5	0 / 2	10	10	BP	●	-	-	-	-	-	-	-	-	❖553G422	
1/2	13	2,49	41,5	0 / 2	10	10	LP	-	●	●	-	●	○	○	-	●	❖553A322	
1/2	13	2,49	41,5	0 / 2	10	10	LP	○	-	-	-	-	-	-	-	-	❖553G322	

❖ Select 8 for NPT ANSI 1.20.3 or select G for ISO G (228/1) ● Available feature ○ Available feature in DC only

(1) Certified IEC 61508 Functional Safety data, use suffix "SL".

(2) Zero minimum is only achieved if external pressure is applied

SPECIFICATIONS

pipe size	orifice size	flow coefficient kv		operating pressure differential (bar)			power level	prefix optional solenoids										basic catalogue number
				min. ⁽²⁾	max. (PS)			NEMA 7 & 9	ATEX / IECEx					IP65				
					air (*)				Ex d	Ex e mb	Ex mb	Ex ia	-					
(*)	(mm)	(m³/h)	(l/min)	~	=	~/=	EF	LPKF	NF	-	EM	PV	(WS)LI	-	SC			
5/3 - W1 - pressure held, solenoid air pilot operated and return																		
1/4	6	0,66	11	0 / 2	10	10	BP	-	-	●	-	●	●	-	●	❖551A438		
1/4	6	0,66	11	0 / 2	10	10	BP	●	-	-	-	-	-	-	-	❖551G438		
1/4	6	0,66	11	0 / 2	10	10	LP	-	●	●	-	●	○	○	-	❖551A338		
1/4	6	0,66	11	0 / 2	10	10	LP	○	-	-	-	-	-	-	-	❖551G338		
5/3 - W3 - pressure release, solenoid air pilot operated and return																		
1/4	6	0,66	11	0 / 2	10	10	BP	-	-	●	-	●	●	-	●	❖551A439		
1/4	6	0,66	11	0 / 2	10	10	BP	●	-	-	-	-	-	-	-	❖551G439		
1/4	6	0,66	11	0 / 2	10	10	LP	-	●	●	-	●	○	○	-	❖551A339		
1/4	6	0,66	11	0 / 2	10	10	LP	○	-	-	-	-	-	-	-	❖551G339		

❖ Select **8** for NPT ANSI 1.20.3 or select **G** for ISO G (228/1) ● Available feature ○ Available feature in DC only
⁽²⁾ Zero minimum is only achieved if external pressure is applied

PREFIX TABLE

prefix							description	power level			
1	2	3	4	5	6	7		LP	RP	MP	BP
E	F						Explosionproof - NEMA 7, 9 - Zinc plated steel conduit	○	-	-	●
E	V						Explosionproof - NEMA 7, 9 - 316 SS conduit	○	-	-	●
E	M						Waterproof IP66/67 - Metal enclosure (EN/IEC 60079-7,-18, -31)*	●	-	-	●
		E	T				Threaded conduit/hole (M20 x 1,5)	●	-	-	●
L	P	K	F				Flameproof - Aluminium (EN/IEC 60079-1, 60079-31)*	●	-	-	●
N	F						Flameproof - Aluminium (EN/IEC 60079-1, 60079-31)*	●	-	-	●
P	V						Encapsulated epoxy moulded (EN/IEC 60079-18)*	○	-	-	●
S	C						Solenoid with spade plug connector (EN/IEC 60730)	●	-	-	●
W	P						Waterproof IP67 - Metal enclosure	●	-	-	●
L	I						I.S. with Aluminium IP67 enclosure (EN/IEC 60079-11, 60079-31)*	○	-	-	●
W	S						Waterproof IP67 - 316 SS enclosure	●	-	-	●
W	S	L	P	K	F		Flameproof - 316 SS (EN/IEC 60079-1, 60079-31)*	●	-	-	●
W	S	E	M				Waterproof IP66/67 - 316 SS enclosure (EN/IEC 60079-7,-18, -31)*	●	-	-	●
W	S			L	I		I.S. with 316L SS IP67 enclosure (EN/IEC 60079-11, 60079-31)*	○	-	-	●
W	S	N	F				Flameproof - 316 SS (EN/IEC 60079-1, 60079-31)*	●	-	-	●
						T	Threaded conduit (1/2" NPT)	●	-	-	●
						H	Class H - High temperature, +80°C ambient temp.	-	-	-	●
						X	Other special constructions	●	-	-	●

SUFFIX TABLE

suffix							description	power level			
1	2	3	4	5	6	7		LP	RP	MP	BP
			M	O			Push type manual operator	○/●	-	-	●
S	L						Certified IEC 61508 Functional Safety data ⁽²⁾	○/●	-	-	●

OPTIONS & ACCESSORIES

series	pipe size	stainless steel exhaust protector		
		G	NPT	(M)
551-553	1/8	34600418 ⁽¹⁾	34600482 ⁽¹⁾	-
551	1/4	34600419 ⁽¹⁾	34600483 ⁽¹⁾	-
553	1/2	34600479 ⁽¹⁾	34600479 ⁽¹⁾	-
551	M5	-	-	34600484 ⁽¹⁾

- Available feature
- Available feature in DC only
- Not available
- * ATEX solenoids are also approved according to EN 13463-1 (non electrical valves)
- ⁽¹⁾ Provided with "SL" suffix
- ⁽²⁾ Not to use with MO suffix

ORDERING EXAMPLES:

SC	G	551	A	421	230V / 50 Hz
SC	G	553	A	421	230V / 50 Hz
SC	G	551	A	421	SL 230V / 50 Hz
SC	G	551	A	422	MO 230V / 50 Hz
SCHT	8	551	A	422	MO 230V / 50 Hz
LPKF	G	551	A	321	MO 24V / DC
WSLPKF	G	551	A	321	MO 230V / 50 Hz
WSLI	G	551	A	321	24V / DC
EM	8	551	A	421	MO 230V / 50 Hz
EF	G	551	G	421	MO 240V / 60 Hz

prefix ⁽³⁾ — pipe thread — basic number ⁽³⁾ — voltage — suffix

⁽³⁾ Prefixes EF and EV should always be used with the letter G in the basic number.

EXPLANATION OF TEMPERATURE RANGES OF SOLENOID VALVES

Valve temperature range The valve temperature range (TS) is determined by the selected seal material, the temperature range for proper operation of the valve and sometimes by the fluid (e.g. steam)

Operator ambient temperature range The operator ambient temperature range is determined by the selected power level and the safety code

Total temperature range The temperature range of the complete solenoid valve is determined by the limitations of both temperature ranges above

ELECTRICAL CHARACTERISTICS

Coil insulation class F
 Electrical safety IEC 335
 Standard voltages DC (=) 24V - 48V
 AC (~) 24V - 48V - 115V - 230V⁽⁶⁾/50Hz; other voltages and 60Hz are available on request

prefix option	power ratings				operator ambient temperature range (TS) (C°) ⁽¹⁾	safety code	electrical enclosure protection (EN 60529)	replacement coil / kit		type ⁽²⁾
	inrush	holding		hot/cold				~	=	
	(VA)	(VA)	(W)	(W)				230 V/50 Hz	24V/DC	
Basic power (BP)										
SC	55	23	10,5	9/11,2	-40 to +75	EN 60730	IP65 moulded	400425-117	400425-142	01
WP/WS	55	23	10,5	9/11,2	-40 to +75	EN 60730	IP67 steel/SS	400405-117	400405-142	04
NF/WSNF	55	23	10,5	-	(-60) ⁽⁷⁾ -40 to +25/40/60	II2G Ex d IIC Gb T6/T5/T4, II2D Ex tb IIIC Db	IP66/67, alu./SS	400405-117	-	02
NF/WSNF	-	-	-	9/11,2	(-60) ⁽⁷⁾ -40 to +40/60/75	II2G Ex d IIC Gb T6/T5/T4, II2D Ex tb IIIC Db	IP66/67, alu./SS	-	400405-142	02
EM/WSEM	55	23	10,5	9/11,2	-40 to +40	II2G Ex e mb IIC Gb T3, II2D Ex tb IIIC Db	IP66/67, steel /SS	400909-117	400913-142	04
PV	55	23	10,5	9/11,2	-40 to +65	II2G Ex mb IIC Gb T3(-)/T4(-), II2D Ex mb IIIC Db	IP67 moulded	- ⁽⁴⁾	- ⁽⁴⁾	05
EF/EV	55	23	10,5	9/11,2	-40 to +54/40	NEMA type 7 and 9	NEMA 4X	238614-058	238714-006	06
Low power (LP)										
SC	1,5	1,5	1,5	1,7/1,7	-40 to +60	EN 60730	IP65 moulded	400925-097	400925-042	07
WP/WS	1,5	1,5	1,5	1,7/1,7	-40 to +60	EN 60730	IP67 steel/SS	400926-097	400926-042	09
LPKF/WSLPKF ⁽⁸⁾	2,4	2,4	2,4	-	-40 to +80/60	II2G Ex d IIB+H2 Gb T6/T5/T4, II2D Ex tb IIIC Db	IP66/67, alu./SS	- ⁽⁴⁾	- ⁽⁴⁾	13
LPKF/WSLPKF	-	-	-	0,5/0,5 ⁽⁸⁾	-40 to +60	II2G Ex d IIB+H2 Gb T6, II2D Ex tb IIIC Db	IP66/67, alu./SS	- ⁽⁴⁾	- ⁽⁴⁾	13
LPKF/WSLPKF	-	-	-	2,1 ⁽⁹⁾	-40 to +40/80	II2G Ex d IIB+H2 Gb T6/T4, II2D Ex tb IIIC Db	IP66/67, alu./SS	- ⁽⁴⁾	- ⁽⁴⁾	13
NF/WSNF	-	-	1,85	- /1,8	(-60) ⁽⁷⁾ -40 to +75/80	II2G Ex d IIC Gb T6/T5, II2D Ex tb IIIC Db	IP66/67, alu./SS	- ⁽⁴⁾ ⁽⁵⁾	- ⁽⁴⁾	08
EM/WSEM	1,5	1,5	1,5	1,7/1,7	-40 to +40/55	II2G Ex e mb IIC Gb T6/T5, II2D Ex tb IIIC Db	IP66/67, steel /SS	- ⁽⁴⁾	- ⁽⁴⁾	09
PV	-	-	-	1,7/1,7	-40 to +65	II2G Ex mb IIC Gb T6, II2D Ex mb IIIC Db	IP67 moulded	- ⁽⁴⁾	- ⁽⁴⁾	10
EF/EV	-	-	-	1,7/1,7	-40 to +60	NEMA type 7 and 9	NEMA 4X	-	- ⁽⁴⁾	11
LI ⁽³⁾ ⁽⁶⁾	-	-	-	0,5/0,5	-40 to +60	II1G Ex ia IIC T6 Ga, II2D Ex tb IIIC Db ⁽⁶⁾	IP66/67, alu.	-	- ⁽⁴⁾	14
WSLI ⁽³⁾ ⁽⁶⁾	-	-	-	0,5/0,5	-40 to +60	II1G Ex ia IIC T6 Ga, II2D Ex tb IIIC Db ⁽⁶⁾	IP66/67, SS	-	- ⁽⁴⁾	14

prefix option	safety parameters				
	U _i = (DC) (V)	I _i (mA)	P _i (W)	L _i (H)	C _i (µF)
Low power (LP)					
LI/WSLI	32	500	1,5	0	0

⁽¹⁾ Temperature range can be limited by sealings
⁽²⁾ Refer to the dimensional drawings on pages:4 to 7
⁽³⁾ LI/WSLI: Check the electrical characteristics in the corresponding catalogue pages
⁽⁴⁾ Multiple coil kits are available under ATEX/IECEx, contact us
⁽⁵⁾ (WS)NF: Low Power, 230 V AC does not exist. Maximum voltage in AC is 115 V
⁽⁶⁾ LI/WSLI: Low Power, 24 V DC only (LI: **For use in zone 0 locations, see the installation conditions given in the I&M instructions**)
⁽⁷⁾ The certified minimum temperature of this operator
⁽⁸⁾ LPKF/WSLPKF: 24 V DC, max. ambient temp. +80°C, contact us (48 V DC = 2,1 W)
⁽⁹⁾ Max. power ratings values: 115 V AC (2,4 W), 48 V DC (2,1 W)
 - Not available

ELECTRICAL CONNECTIONS

prefix	connection
SC	Spade plug connector with cable gland EN175301-803A (ISO 4400) for cables with an outer diameter from 6 to 10 mm
WP, WS, EM, WSEM	M20 cable gland for cables with an outer diameter from 7 to 12 mm. With an internal and external facility for an earthing or bonding conductor
NF, WSNF, LPKF, WSLPKF	1/2" NPT threaded cable entry. Enclosures are supplied without cable gland
PV	Moulded-in cable, standard length 2 m
LI, WSLI	1/2" NPT cable gland for cables with an outer diameter from 7 to 12 mm. With an internal and external facility for an earthing or bonding conductor
EF, EV	1/2" NPT conduits, standard length 35 cm

ADDITIONAL OPTIONS

- Valves configured for external pilot air supply, TPL 20547
- Other pipe threads are available on request
- Ex mb (prefix "PV") solenoid can be supplied with various cable lengths
- Compliance with "UL", "CSA" and other local approvals available on request
- 1/2" NPT (prefix "T") and M20 x 1.5 (prefix "ET") conduits (aluminium or 316 SS) available for steel solenoid housing

INSTALLATION

- Multi language installation/maintenance instructions are included with each valve
- The solenoid valves can be mounted in any position without affecting operation
- Do not connect the pressure supply to the exhaust port 3. The "environmentally-protected" construction is not adapted for a "distributing" function or use in NO function. Contact us for functions available in specific versions
- IEC 61508 Functional Safety (suffix SL). Check temperature range of valve body and solenoid for suitability. For probability of failure, contact us
- It is necessary to connect pipes or fittings to the exhaust ports to protect the internal parts of the spool valve and its pneumatic operator if used outside or in harsh environments (dusts, liquids etc.)
- Threaded pipe connection identifier is: 8 = NPT (ANSI 1.20.3); G = G (ISO 228/1)
- Prefix "NF/WSNF" enclosure is provided with a 1/2" NPT threaded entry hole, M20 x 1,5 (prefix "ET") is optional. Both are supplied without cable gland

DIMENSIONS (mm), WEIGHT (kg)

Series 551

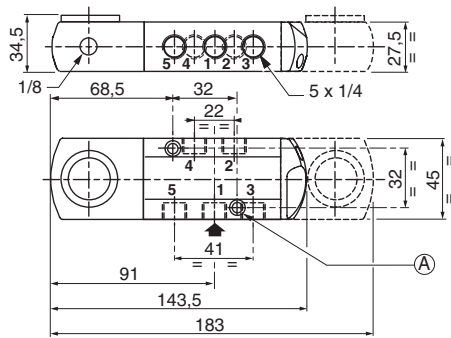

Series 553

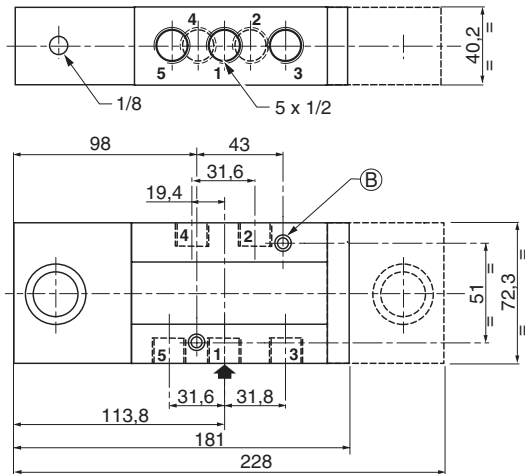

2 mounting holes

- (A) 5.3 mm dia.; Spotfacing: 9 mm dia., depth 5 mm
- (B) 6.5 mm dia.; Spotfacing: 11 mm dia., depth 6 mm



TYPE 01:

Epoxy moulded
SC: IEC 335 / ISO 4400

551A421 / 551A422 / 551A438 / 551A439 / 553A421 / 553A422



TYPE 02:

Aluminium; epoxy coated / AISI 316L SS
NF/WSNF: EN/IEC 60079-1, 60079-31

551A421 / 551A422 / 551A438 / 551A439 / 553A421 / 553A422

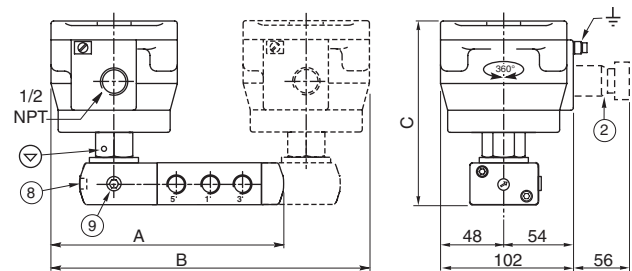
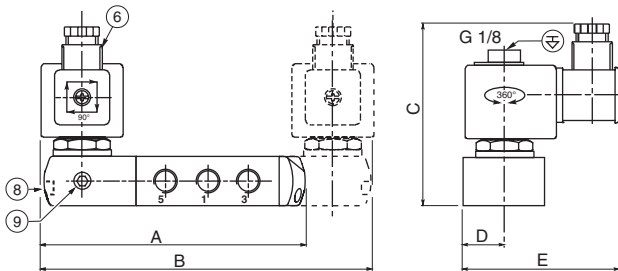

TYPE 04:

Metal; epoxy coated / AISI 316 SS
WP / WS: IEC 335
EM / WSEM: EN/IEC 60079-7 +18 + 31

551A421 / 551A422 / 551A438 / 551A439 / 553A421 / 553A422

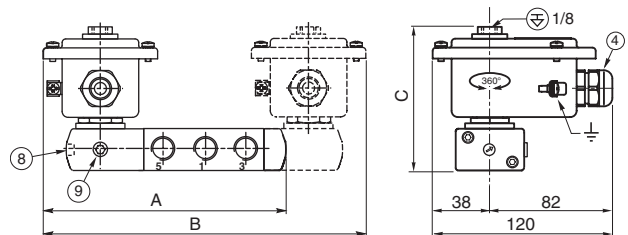

DIMENSIONS (mm), WEIGHT (kg)



TYPE 05:
Epoxy encapsulated
PV: EN/IEC 60079-18

551A421 / 551A422 / 551A438 / 551A439 / 553A421 / 553A422

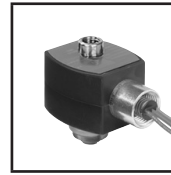
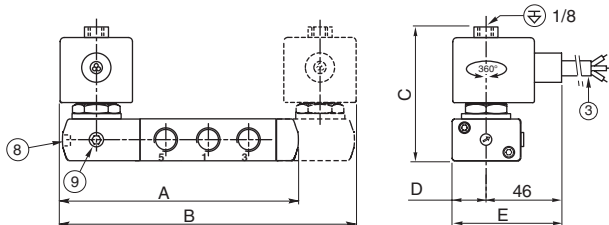

TYPE 06:
Epoxy encapsulated
EF/EV: NEMA type 7, 9 / ICS-6 ANSI
NOTE: applicable to solenoid only

551G421 / 551G422 / 551G438 / 551G439 / 553G421 / 553G422

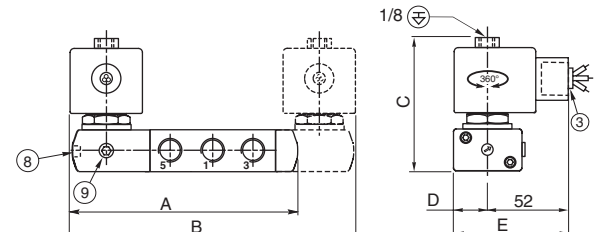

TYPE 07:
Epoxy moulded
SC: IEC 335 / ISO 4400

551A321 / 551A322 / 551A338 / 551A339 / 553A321 / 553A322

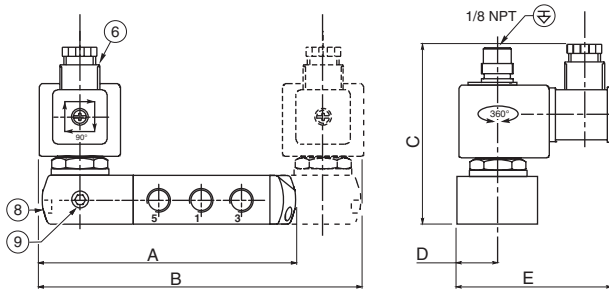

TYPE 08:
Aluminium; epoxy coated / AISI 316L SS
NF/WSNF: EN/IEC 60079-1, 60079-31

551A321 / 551A322 / 551A338 / 551A339 / 553A321 / 553A322

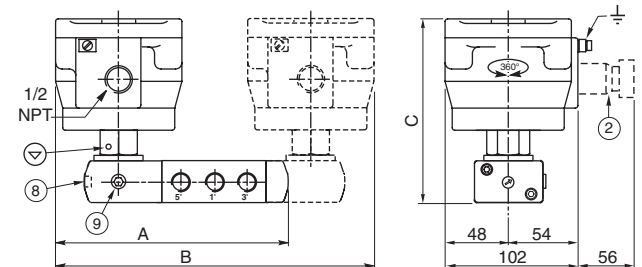

TYPE 09:
Metal; epoxy coated / AISI 316 SS
WP / WS: IEC 335
EM / WSEM: EN/IEC 60079-7 +18 + 31

551A321 / 551A322 / 551A338 / 551A339 / 553A321 / 553A322

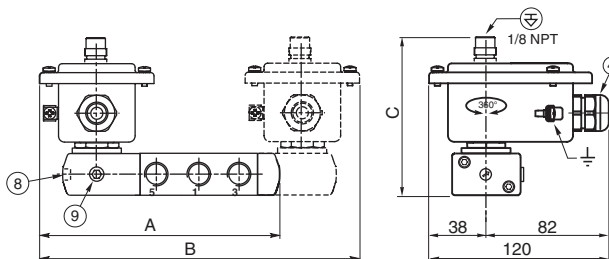

TYPE 10:
Epoxy encapsulated
PV: EN/IEC 60079-18

551A321 / 551A322 / 551A338 / 551A339 / 553A321 / 553A322

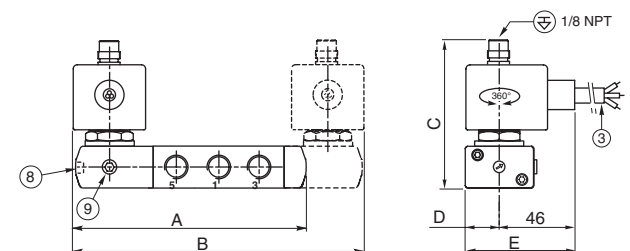

DIMENSIONS (mm), WEIGHT (kg)



TYPE 11:
Epoxy encapsulated
EF/EV: NEMA type 7, 9 / ICS-6 ANSI
NOTE: applicable to solenoid only

551G321 / 551G322 / 551G338 / 551G339 / 553G321 / 553G322

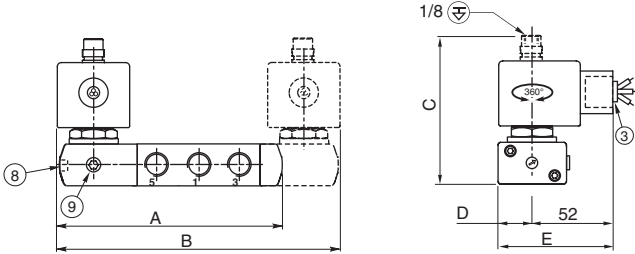

TYPE 13:
Aluminium, cataphoresis black painting / AISI 316L SS
LPKF/WSLPKF: EN/IEC 60079-1, 60079-31

551A321 / 551A322 / 551A338 / 551A339 / 553A321 / 553A322

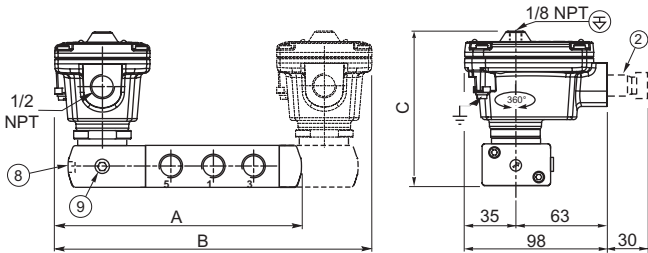

TYPE 14:
Aluminium, cataphoresis black painting / AISI 316L SS
LI / WSLI : EN/IEC 60079-11, 60079-31

551A321 / 551A322 / 551A338 / 551A339 / 553A321 / 553A322

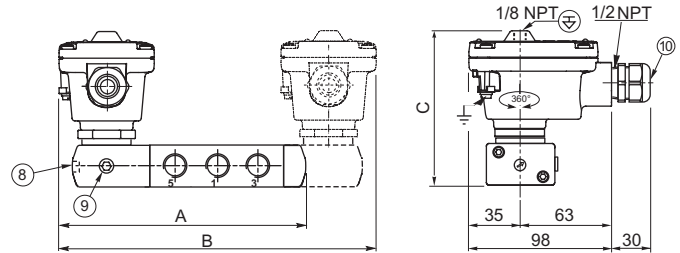

DIMENSIONS (mm), WEIGHT (kg)

type	prefix option	power level	551					553					weight ⁽¹⁾			
			A	B	C	D	E	A	B	C	D	E	monostable		bistable	
01	SC	basic power	144	184	103	22,5	87	182	229	109	36,5	101	1,27	3,06	2,03	4,38
02	NF	basic power	170	236	142	-	-	208	281	148	-	-	2,42	4,21	4,13	6,48
02	WSNF	basic power	170	236	142	-	-	208	281	148	-	-	3,72	5,51	6,73	9,08
04	WP / WS / EM / WSEM	basic power	160	216	103	-	-	198	261	109	-	-	1,70	3,49	2,69	5,04
05	PV	basic power	144	184	88	22,5	69	182	229	94	36,5	82,5	1,37	3,16	2,03	4,38
06	EF / EV	basic power	145	185	86	22,5	75	183	230	92	36,5	88,5	1,37	3,16	2,03	4,38
07	SC	low power	145	185	102	22,5	88	183	230	108	36,5	102	1,27	3,06	2,03	4,38
08	NF	low power	170	236	142	-	-	208	281	148	-	-	2,42	4,21	4,13	6,48
08	WSNF	low power	170	236	142	-	-	208	281	148	-	-	3,72	5,51	6,73	9,08
09	WP / WS / EM / WSEM	low power	160	216	102	-	-	198	261	108	-	-	1,70	3,49	2,69	5,04
10	PV	low power	144	184	101	22,5	69	182	229	107	36,5	82,5	1,37	3,16	2,03	4,38
11	EF / EV	low power	145	185	101	22,5	75	182	230	107	36,5	88,5	1,37	3,16	2,03	4,38
13	LPKF	low power	153	204	113	-	-	193	252	118,7	-	-	1,39	4,48	2,31	4,68
13	WSLPKF	low power	153	204	113	-	-	193	252	118,7	-	-	2,00	3,15	3,51	5,75
14	LI	low power	153	204	113	-	-	193	252	118,7	-	-	1,40	4,49	2,32	4,69
14	WSLI	low power	153	204	113	-	-	193	252	118,7	-	-	2,01	3,16	3,52	5,76

⁽¹⁾ Incl. coil(s) and connector(s)

- ② Ex d certified cable gland (on request)
- ③ Three-core cable, length 2 m
- ④ Cable gland for unarmoured cable with 7 to 12 mm dia. sheath
- ⑥ Connector rotatable by 90° increments (cable Ø 6 - 10 mm)
- ⑧ Manual operator location, suffix MO
- ⑨ External pilot air supply, 1/8 pipe size
- ⑩ Cable gland for unarmoured cable with 7 to 12 mm dia. sheath
- ⊕ Connectable pilot exhaust port
- ⊖ Non-connectable pilot exhaust port

ACCESSORIES

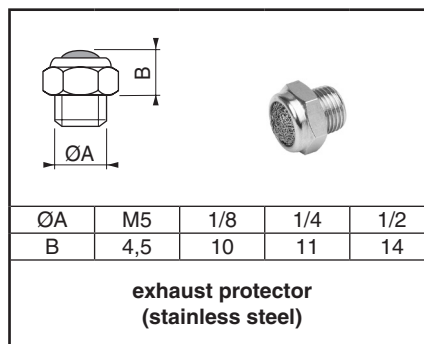
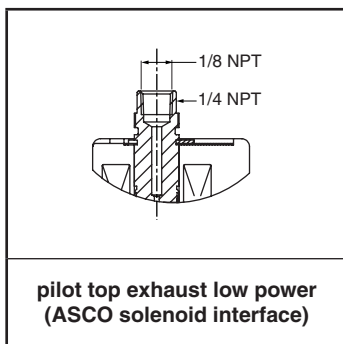
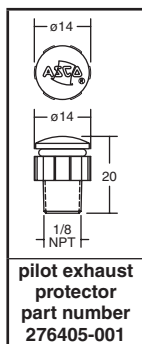



Pilot Operated
Direct Mount Inline Spool Valves
 Anodized Aluminum Bodies • Direct NAMUR Mount
 1/4" and 1/2" NPT

**3/2•5/2
 SERIES
 8551, 8553
 Direct
 Mount**

Features

- Compact spool valve convertible from 3/2 to 5/2
- NAMUR mount construction
- Standard manual operator
- DIN, Watertight and Explosionproof solenoids available
- Single and dual solenoid constructions
- Mountable in any position
- Vents air from spring side of actuator to prevent corrosion of actuator

Construction

Valve Parts in Contact with Fluids	
Body	Black Anodized Aluminum
Spring	Phosphate treated black steel
Shading Coil	Copper
Seals	NBR + PUR
Core and Core Tube	Stainless Steel / Brass
End Covers and Plate	6/6 glass filled PA/FV
Spool	Aluminum
Internal Parts	Zamak, Steel, CA

Electrical

Standard Coil and Class of Insulation	Enclosure Type	Watt Rating and Power Consumption				Spare Coil Part Number	
		DC Watts	AC Watts	VA Holding	VA Inrush	AC	DC
F	SC	3	2.5	3.5	6	400127	400127
F	SC	6.9	5	7	15	400727	400727
F	EF	6.9	6.3	7	10.1	266762	270007
F	WT	6.9	6.3	7	10.1	266763	270008

Standard Voltages: SC: 24, 120, 240 Volts AC, 50-60 Hz; 12, 24, 120 Volts DC.
 WT and EF: 24/50-60HZ, (120/60, 110-120/50)①, (240/60, 220-240/50)② Volts AC;
 6, 12, 24, 120 Volts DC.
 ① Order as 120/60, 110/50
 ② Order as 240/60, 220/50

Solenoid Enclosures

Standard: - Prefix

SC = IP65 type DIN (open frame) per 46244

WT = Combination General Purpose and Watertight Types 1, 2, 3, 3S, 4, and 4X

EF = Combination Explosionproof and Watertight Types 3, 3S, 4, 4X, 6, 5P, 7, 9 Class I, Div. 1 (Groups A - D) and Class II, Div. 1 Type 9 (Groups E-G)

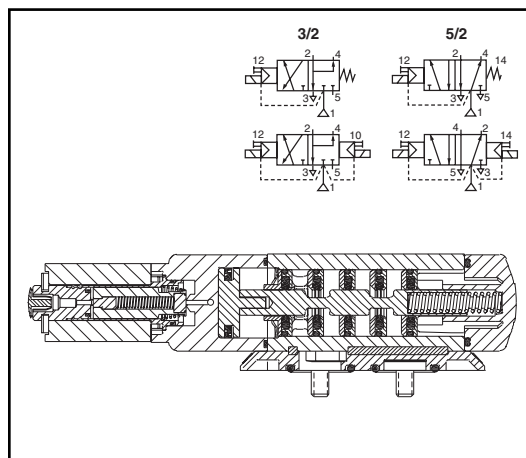

VALVE AUTOMATION

Nominal Ambient Temp. Ranges

SC: AC/DC: 5°F to +140°F (-15°C to 60°C)

EF: AC: 5°F to +104°F (-15°C to 40°C)
 DC: 5°F to +77°F (-15°C to 25°C)

WT: AC: 5°F to +140°F (-15°C to 60°C)
 DC: 5°F to +77°F (-15°C to 25°C)

Note: For temperatures below 32°F (0°C) moisture-free air must be used.

Refer to Engineering Section for details.

Approvals

SC (2.5W and 3W only) UL recognized component, CSA certified. (Series 8551 only)

WT: UL listed, CSA certified. (Series 8551 only)

EF: UL and CSA listed solenoid.
 Meets applicable CE directives.

SIL 3 capable per IEC 61508 on normally closed single solenoid. Third party certification provided by EXIDA.

Refer to Engineering Section for details.

Specifications (English units)

Pipe Size (in)	Orifice Size (in)	Cv Flow Factor	Operating Pressure Differential (psi)		Fluid Temperature °F (for single and dual solenoid)			Single Solenoid PFD _{AVG} = 3.3 x 10 ⁻³	Dual Solenoid	Const. Ref.	Watt Rating/ Class of Coil Insulation	
			Min.	Max.	Min.	Max. AC	Max. DC				AC	DC
OPEN FRAME DIN COIL												
1/4 ①	1/4	.86	30	150	5	140	140	SC8551A001MS	SC8551A002MS	1	2.5	3
1/2	1/2	3.7	30	150	-15	140	140	SC8553A001MS	SC8553A002MS	2	5	6.9
WATERTIGHT ENCLOSURE												
1/4 ①	1/4	.86	30	150	5	140	77	WT8551A001MS	WT8551A002MS	1	6.3	6.9
1/2	1/2	3.7	30	150	-15	140	77	WT8553A001MS	WT8553A002MS	2	6.3	6.9
EXPLOSIONPROOF ENCLOSURE												
1/4 ①	1/4	.86	30	150	5	104	77	EF8551A001MS	EF8551A002MS	1	6.3	6.9
1/2	1/2	3.7	30	150	-15	104	77	EF8553A001MS	EF8553A002MS	2	6.3	6.9

① 1/8 inch NPT exhausts.

Specifications (Metric units)

Pipe Size (in)	Orifice Size (mm)	Kv Flow Factor (m ³ /h)	Operating Pressure Differential (bar)		Fluid Temperature °C (for single and dual solenoid)			Single Solenoid PFD _{AVG} = 3.3 x 10 ⁻³	Dual Solenoid	Const. Ref.	Watt Rating/ Class of Coil Insulation	
			Min.	Max.	Min.	Max. AC	Max. DC				AC	DC
OPEN FRAME DIN COIL												
1/4 ①	6.4	.7	2	10	-15	60	60	SC8551A001MS	SC8551A002MS	1	2.5	3
1/2	13	3.15	2	10	-25	60	60	SC8553A001MS	SC8553A002MS	2	5	6.9
WATERTIGHT ENCLOSURE												
1/4 ①	6.4	.7	2	10	-15	60	25	WT8551A001MS	WT8551A002MS	1	6.3	6.9
1/2	13	3.15	2	10	-25	60	25	WT8553A001MS	WT8553A002MS	2	6.3	6.9
EXPLOSIONPROOF ENCLOSURE												
1/4 ①	6.4	.7	2	10	-15	40	25	EF8551A001MS	EF8551A002MS	1	6.3	6.9
1/2	13	3.15	2	10	-25	40	25	EF8553A001MS	EF8553A002MS	2	6.3	6.9

① 1/8 inch NPT exhausts.

Dimensions inches (mm)

Series	8551
NPT	1/4
L1	5.47 (139)
L2	7.56 (192)
H1	1.30 (33)
W	1.77 (45)

**NOTE: Valve shown with CM22
DIN terminal coil and connector.
Connector sold separately.**

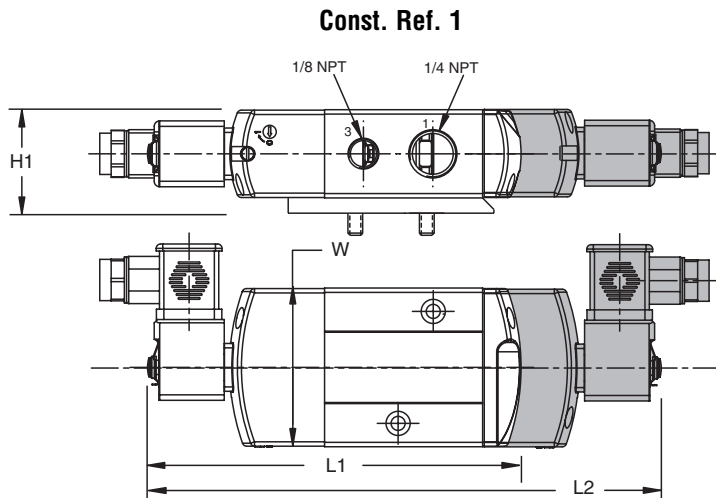

8551 NAMUR Footprint

Series	8553
NPT	1/2
L1	7.76 (197)
L2	10.25 (260)
H1	1.94 (49)
W	2.85 (72)

**NOTE: Valve shown with CM22
DIN terminal coil and connector.
Connector sold separately.**

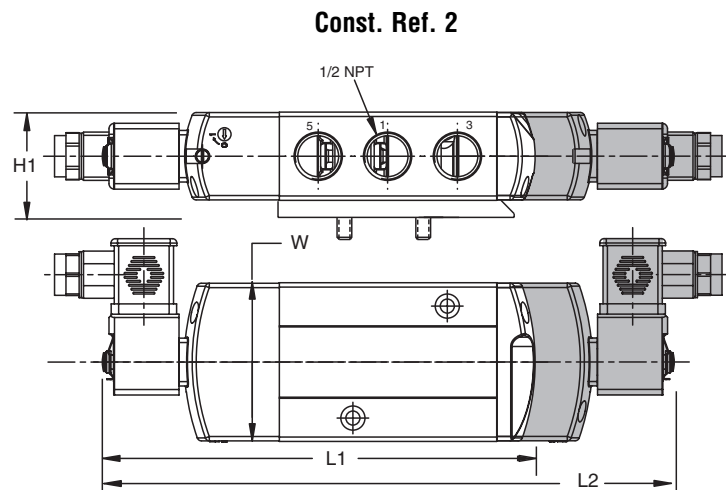

8553 NAMUR Footprint