

# IMI PBM RADIAL TANK OUTLET VALVES

## RD SERIES, Sizes 1/2" - 3"



### DESIGN FEATURES:

- Smooth sloping design for complete drainage
- 45° and 2° sloped outlet
- Machined by IMI PBM from wrought material
- All internal surfaces 15 Ra or better after electropolish
- Diaphragm seal easily removed for quick change-out
- Silicone Diaphragm is medical grade platinum cured
- Full material traceability and documentation package
- Optional purge port or Satellite valve mounted on the body opposite outlet is available
- Exceeds performance requirements of ASME-BPE testing
- CRN (Canadian Registration Numbers) available on request



SPECIFICATIONS	RD VALVE
Sizes	1/2" - 3"
Body and Weld pad	316L Stainless, Hastelloy® C-22®, AL6XN, others available
Maximum Working Pressure	175 psig CWP
Diaphragm/Gasket Materials	Silicone or V-TEF™
Temperatures	Silicone to -60°F to 275°F, V-TEF 32°F to 400°F

WEIGHTS (lbs.)				
Size	Valve, manual	Valve + actuator	Valve + clamp, manual	Valve + Clamp + actuator
1/2"	3.14	4.46	2.87	4.20
3/4"	3.17	4.32	3.00	4.15
1"	7.10	9.50	6.53	8.90
1-1/2"	8.56	14.20	9.16	14.00
2"	15.90	21.90	15.10	21.00
3"	31.80	62.80	27.70	59.70

CV Values (gpm)	
Size	gal./min.
1/2"	3.30
3/4"	10.30
1"	14.60
1-1/2"	48.10
2"	72.20
3"	167.70

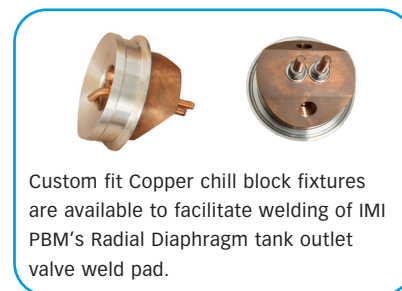

Custom fit Copper chill block fixtures are available to facilitate welding of IMI PBM's Radial Diaphragm tank outlet valve weld pad.

CHILL KITS	
Size	IMI PBM PART #
1"	RDCUE1--CHILL-KIT
1-1/2"	RDCUG1--CHILL-KIT
2"	RDCUH1--CHILL-KIT
3"	RDCUK1--CHILL-KIT

### How To Order:

PRODUCT (1-2) MATERIAL (3-4)		SIZE (5) SERIES (6)	OUTLET END CONN. (7)	OUTLET ORIENTATION CONNECTION (8)	DIAPHRAGM /GASKET (9)	TANK PAD OPTIONS (10-11)	PURGE PORTS (12)	OPERATOR (13-14)	POLISH (MECH. UNLESS NOTED) (15-16)
RD	HL 316L Stainless	C 1/2"	I F Extended Butt Weld	1 2° Slope W/ Straight Outlet	B Silicone/Silicone	-- Standard Weld Pad	- No purge option(s) selected	-- w/Manual Knob	G 15Ra ID / 63Ra OD after EP (Standard)
	Y- Hastelloy® C-22®	D 3/4"	X Hygienic Clamp	2 2° Slope W/ 45° Outlet	G V-TEF™	LP Less Weld Pad	A (1) 1/2" clamp on center opposite outlet	34 SR80 psig actr	H 10Ra ID / 63Ra OD after EP
	P- AL6XN	E 1"		3 Tangential 2° slope W/ Straight Outlet	H V-TEF™/EPDM	CX 1/2" Clamp Inlet	B (1) 1/2" BWTE on center opposite outlet	35 SR80 psig actr & GP LS	O 15Ra ID / 32Ra OD / EP
		G 1-1/2"		4 Tangential 2° slope W/ 45° Outlet	I V-TEF™/FKM	DX 3/4" Clamp Inlet	R (1) 1/2" Satellite Valve - Hygienic Clamp - Manual	37 SR80 psig actr & GP Limit switch & 120VAC Solenoid	S 10Ra ID / 32Ra OD / EP
		H 2"				EX 1" Clamp Inlet	S (1) 1/2" Satellite Valve - Ext. Butt Weld - Tube - Manual	64 SR80 psig actr & GP Limit switch & 24VDC Solenoid	
		K 3"				GX 1-1/2" Clamp Inlet			
						HX 2" Clamp Inlet			
						KX 3" Clamp Inlet			
						W4 1/2" Thick Weld Pad	Other purge port / satellite valve options - Consult factory.		
						W6 3/4" Thick Weld Pad			

<https://pbmvalve.com/build-a-part-number>

# IMI PBM Radial Diaphragm Valve Dimensions

Flush Mounted Radial Diaphragm Valves

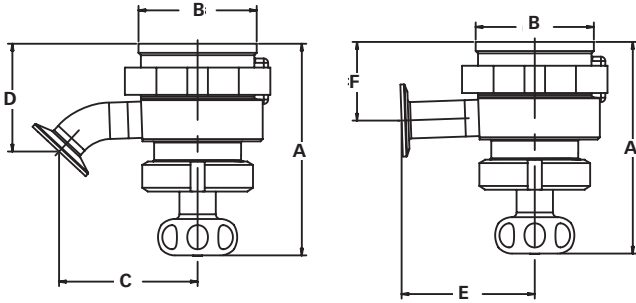

Size	Port	A	B	C	D	E	F
1/2"	0.37	5.07	2.25	3.11	2.64	3.18	1.93
3/4"	0.62	5.07	2.25	3.11	2.50	3.18	1.80
1"	0.87	5.82	3.25	3.81	2.95	3.66	2.15
1-1/2"	1.37	6.36	3.25	4.32	3.44	3.66	2.40
2"	1.87	7.14	4.25	5.34	4.05	4.65	2.79
3"	2.87	9.26	6.25	7.34	5.72	5.59	3.98

Clamp Mounted Radial Diaphragm Valves

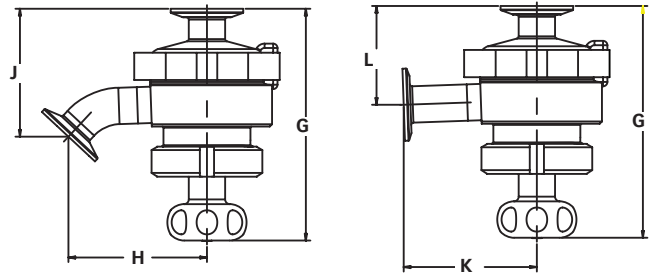

Size	Port	G	H	J	K	L
1/2"	0.37	5.82	3.11	3.39	3.18	2.68
3/4"	0.62	5.82	3.11	3.25	3.18	2.55
1"	0.87	6.37	3.81	3.51	3.66	2.61
1-1/2"	1.37	6.91	4.32	3.99	3.66	2.86
2"	1.87	7.69	5.34	4.60	4.65	3.34
3"	2.87	9.39	7.34	5.85	5.59	4.11

Actuated Flush Mounted Radial Diaphragm Valves

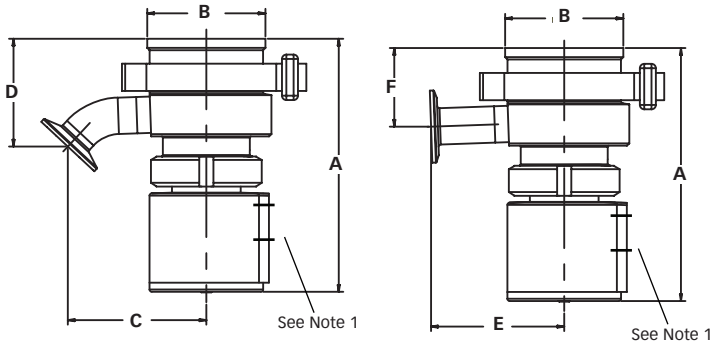

Size	Port	A	B	C	D	E	F
1/2"	0.37	6.08	2.25	3.11	2.64	3.18	1.93
3/4"	0.62	6.08	2.25	3.11	2.50	3.18	1.80
1"	0.87	6.96	3.25	3.81	2.95	3.66	2.15
1-1/2"	1.37	8.24	3.25	4.32	3.44	3.66	2.40
2"	1.87	9.42	4.25	5.34	4.05	4.65	2.79
3"	2.87	13.42	6.25	7.34	5.72	5.59	3.98

Note 1: Air connection on actuator is 1/8" F.N.P.T.

Actuated Clamp Mounted Radial Diaphragm Valves

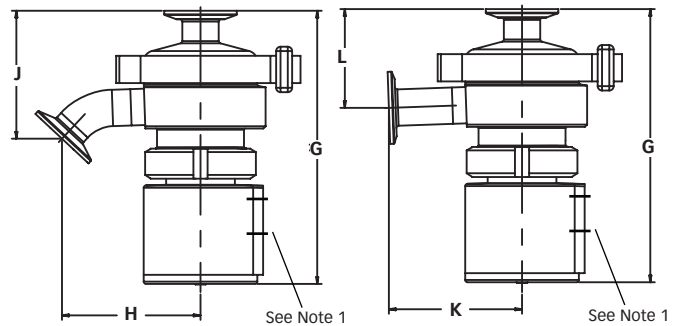

Size	Port	G	H	J	K	L
1/2"	0.37	6.83	3.11	3.39	3.18	2.69
3/4"	0.62	6.83	3.11	3.25	3.18	2.55
1"	0.87	7.51	3.81	3.51	3.66	2.61
1-1/2"	1.37	8.79	4.32	3.99	3.66	2.86
2"	1.87	9.97	5.34	4.60	4.65	3.34
3"	2.87	13.62	7.34	5.84	5.59	4.11

[www.PBMValve.com](http://www.PBMValve.com)

PBM, Inc. • 1070 Sandy Hill Road, Irwin, PA 15642

Phone: 800.967.4PBM • 724.863.0550

E-mail: [info.pbmvalve@imi-critical.com](mailto:info.pbmvalve@imi-critical.com)

**IMI** Critical  
Engineering



© Copyright 2020 PBM, Inc. LT PB-RDV

# IMI PBM POLYMER RADIAL TANK OUTLET VALVES

## RD Series, Sizes 1" - 2"



### DESIGN FEATURES:

- Smooth sloping design for complete drainage
- 2° sloped outlet
- Machined from polypropylene or PVDF material
- Outlet sizes can be customized upon request - Contact IMI PBM
- Diaphragm seal easily removed for quick change-out
- Silicone diaphragm is medical grade platinum cured
- Full material traceability and documentation package
- Exceeds performance requirements of ASME-BPE testing



SPECIFICATIONS	RD VALVE
Sizes	1" - 2"
Maximum Working Pressure	10 PSIG CWP
Diaphragm/Gasket Materials	Silicone or V-TEF™
Maximum Service Temperature	Polypropylene (104°C / 220°F), PVDF (110°C / 230°F)

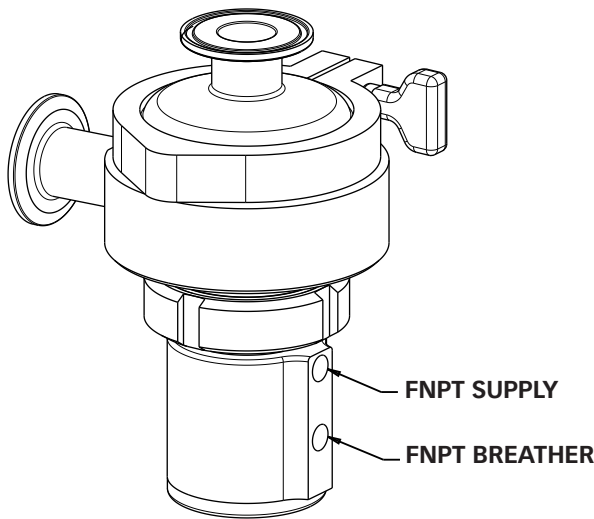

WEIGHTS (lbs.)		
Size	Manual	Actuated
1"	4.7	5.8
1-1/2"	6.0	9.0
2"	9.2	13.4

CV Values (gpm)	
Size	gal./min.
1"	14.60
1-1/2"	48.10
2"	72.20

### How To Order:

PRODUCT (1-2)/MATERIAL (3-4)			SIZE (5) SERIES (6)		OUTLET END CONN. (7)		OUTLET ORIENTATION CONNECTION (8)		DIAPHRAGM /GASKET (9)		PURGE PORTS (12)		OPERATOR (13-14)		
RD	PP	Polypropylene	E	1"	1	X	Hygienic Clamp	1	2° Slope W/ Straight Outlet	B	Silicone/Silicone	-	No purge option(s) selected	--	w/Manual Knob
			G	1-1/2"				3	Tangential 2° slope W/ Straight Outlet	G	V-TEF™	A	(1) 1/2" clamp on center opposite outlet	20	SR80 psig actr
			H	2"						H	V-TEF™/EPDM	B	(1) 1/2" BWTE on center opposite outlet	21	SR80 psig actr & GP LS
										I	V-TEF™/FKM	R	(1) 1/2" Satellite Valve - Hygienic Clamp - Manual	23	SR80 psig actr & GP Limit switch & 120VAC Solenoid
												S	(1) 1/2" Satellite Valve - Ext. Butt Weld - Tube - Manual	56	SR80 psig actr & GP Limit switch & 24VDC Solenoid

X1 = STANDARD STRAIGHT OUTLET  
X3 = TANGENTIAL OUTLET

<https://pbmvalve.com/build-a-part-number>

Other purge port / satellite valve options - Consult factory.

# IMI PBM Polymer Radial Diaphragm Valve Dimensions

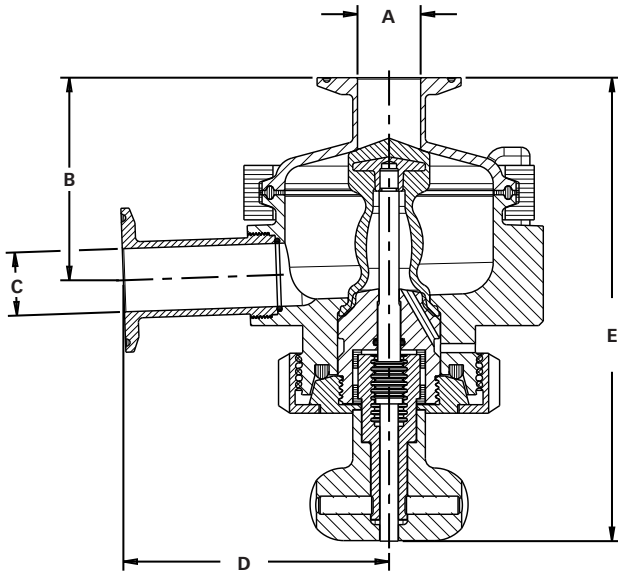

Manual Clamp Mounted Radial Diaphragm Valves

Size	A	B	C	D	E (Open)	E (Closed)
1"	0.87"	2.79"	0.87"	3.66"	6.69"	6.38"
1-1/2"	1.37"	3.08"	1.37"	3.65"	7.41"	6.91"
2"	1.87"	3.40"	1.87"	4.65"	10.11"	9.51"

Actuated Clamp Mounted Radial Diaphragm Valves

Size	A	B	C	D	E (Open)	E (Closed)
1"	0.87"	2.79"	0.87"	3.66"	7.63"	7.32"
1-1/2"	1.37"	3.08"	1.37"	3.65"	9.25"	8.75"
2"	1.87"	3.40"	1.87"	4.65"	10.11"	9.51"

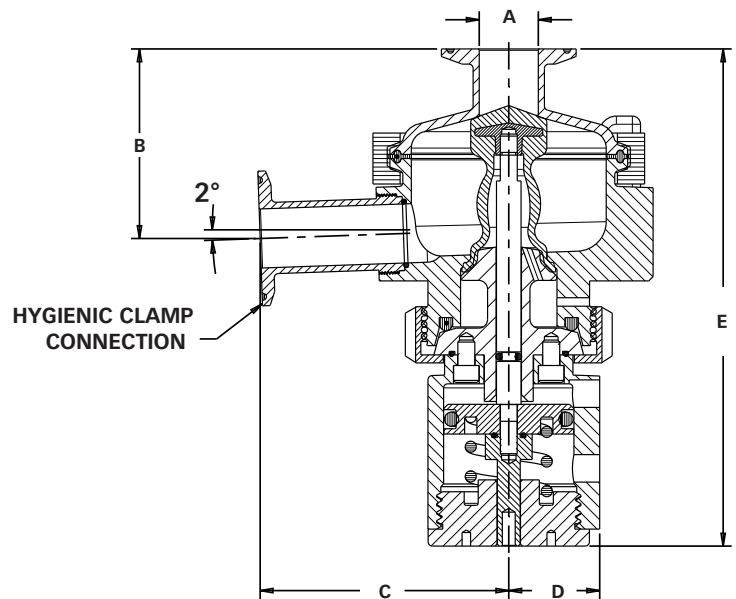

[www.PBMVALVE.com](http://www.PBMVALVE.com)

PBM, Inc. • 1070 Sandy Hill Road, Irwin, PA 15642

Phone: 800.967.4PBM • 724.863.0550

E-mail: [info.pbmvalve@imi-critical.com](mailto:info.pbmvalve@imi-critical.com)

